



FUEL MANAGEMENT SYSTEMS



DISPENSERS



KITS



PUMPS



METERS



NOZZLES

SELF SERVICE K44

FEATURES

- ALL-IN-ONE EQUIPMENT
- WATER CAPTOR FILTER
- COMPACT DESIGN
- IP55

The PIUSI SELF SERVICE K44 is a fuel dispenser unit equipped with a high capacity vane pump, built-in bypass valve and mechanical K44 meter. Particularly suitable for all the needs of high-flow rate diesel dispensing, it guarantees that the dispensed product is free of water and impurities thanks to the integrated filter (column version). Available both as column or tank version, it features a front door for easy maintenance.

PERFORMANCE

UP TO

90 L/MIN

FLOW RATE

AC

CONTINUOUS DUTY

POWER

±1%

ACCURACY



MECHANICAL METER INTEGRATED



SELF SERVICE K44

PACKAGING

CODE	WEIGHT		PACKAGING			N. BOXES / EUROPALET	
	KG	LBS	MM	INCH	PCS/BOX	✈	🚛

COLUMN VERSIONS

FO073701B	67	148	1478X488X400	-	1	6	4
FO074001B	75	165	1478X488X400	-	1	6	4
FO074002A	75	165	1478X488X400	-	1	6	4

TANK VERSIONS

FO0737B0B	57	126	1080X488X400	-	1	6	4
FO0740B0B	65	143	1080X488X400	-	1	6	4
FO0737B2B	57	126	1080X488X400	-	1	6	4



FILTRATION



TANK MONITORING



HOSE REEL



ACCESSORIES



MERCHANDISE



AIR



ANTIFREEZE



AdBlue®



BIODIESEL



DIESEL



FOOD



GASOLINE



GREASE



KEROSENE



OIL



WATER



WINDSCREEN

CHART

PANTHER 72 / E120

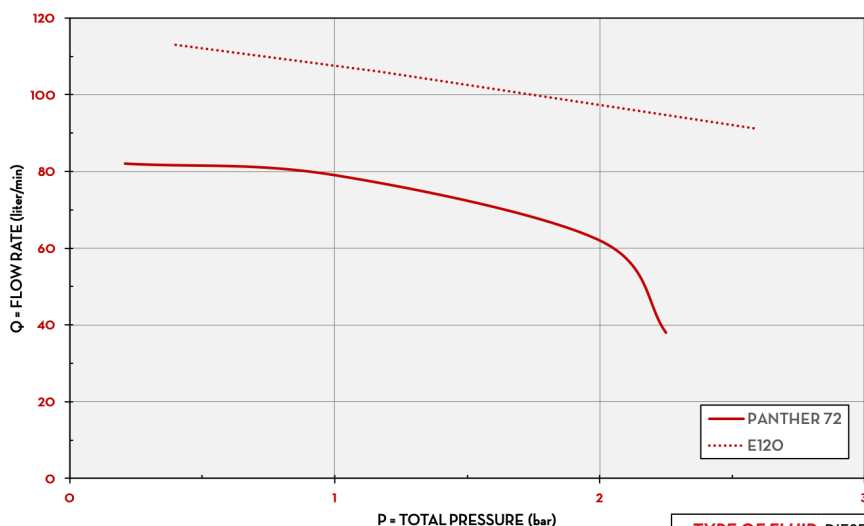

TYPE OF FLUID DIESEL
TEMPERATURE 20/23 °C

IN THE BOX

- SELF SERVICE K44 DISPENSER
- DELIVERY HOSE
- AUTOMATIC NOZZLE
- INSTRUCTION MANUAL

DETAILS



DIMENSIONS

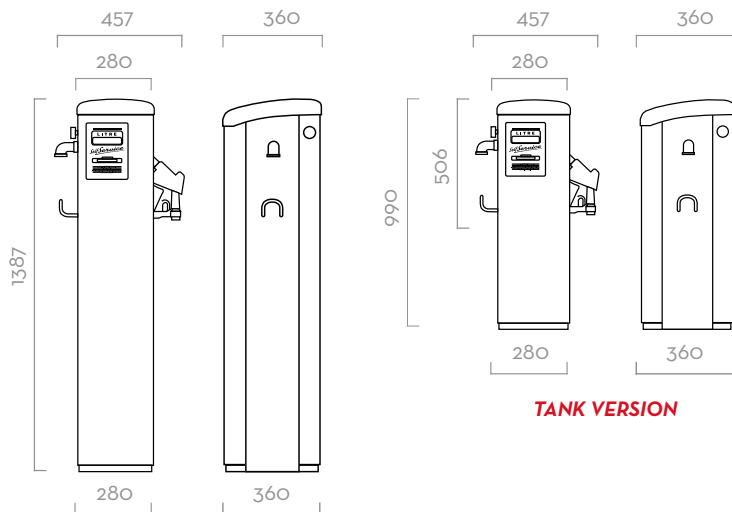

COLUMN VERSION

TANK VERSION

Dimensions expressed in millimeters

COMPONENTS

- **PUMPS:**
PANTHER AC / E120 PAG. 102/106
- **METERS**
K44 PAG. 146
- **NOZZLE:**
AUTOMATIC NOZZLE PAG. 158
- **FILTER:**
WATER CAPTOR PAG. 170

TECHNICAL DATA

CODE	DESCRIPTION	FLUIDS TYPE	FLOW RATE		VOLTAGE			PUMP	METER	NOZZLE	FILTER		INLET	HOSE LENGTH	PC
			L/MIN	GPM	AC V/Hz	DC VOLT	POWER WATT				AMP. MAX.	H2O FILTER			

COLUMN VERSIONS

FO073701B	SELF SERVICE 70 K44	D	70	18	230/50	550	3,3	PANTH 72	K44	A80	YES	30µ	1" 1/2	4	NO
FO074001B	SELF SERVICE 100 K44	D	90	24	230/50	1150	5,7	E 120	K44	A120	YES	30µ	1" 1/2	4	NO
FO074002A	SELF SERVICE 100 K44 PULSER	D	90	24	230/50	1150	5,7	E 120	K44 P	A120	YES	30µ	1" 1/2	4	NO

TANK VERSIONS

FO0737BOB	SELF SERVICE 70 K44 TANK	D	70	18	230/50	550	3,3	PANTH 72	K44	A80	NO	-	1" 1/2	4	NO
FO0740BOB	SELF SERVICE 100 K44 TANK	D	90	24	230/50	1150	5,7	E 120	K44	A120	NO	-	1" 1/2	4	NO
FO0737B2B	SELF SERVICE 70 K44 TANK PULSER	D	70	18	230/50	550	3,3	PANTH 72	K44 P	A80	NO	-	1" 1/2	4	NO

UPON REQUEST IT IS AVAILABLE WITH DIFFERENT VOLTAGES AND 60 HZ FREQUENCY

SELF SERVICE K44