



FUEL MANAGEMENT SYSTEMS



DISPENSERS



KITS



PUMPS



METERS



NOZZLES

# MCBOX B.SMART

## FEATURES

- IDEALS FOR EXISTING PLANTS
- SUITABLE FOR ANY PUMPS
- PULSE METER INPUT
- NATIVE WITH B.SMART CLOUD SOFTWARE
- AVAILABLE IN COMPACT VERSION

MCBOX is an electronic control panel that allows you to control any type of AC/DC pump, pulser litre-counter, nozzle and fuel level switches. The perfect product to upgrade an existing installation or for a customized assembly. With MC BOX B.SMART the B.SMART fuel management system is integrated. No need for software to be installed on a PC: B.SMART works in the Cloud and allows you to monitor all fuel transactions in real time, from any site where MCBOX B.SMART is installed. Communication between MCBOX B.SMART, Phone App and Cloud Software is simple. Also available in a compact version for installations in confined spaces.

### PERFORMANCE

**AC/DC**

VOLTAGE

UP TO  
**500**  
STORABLE  
TRANSACTIONS

**2 PUMPS  
VERSION**

OUTPUT

**BLUETOOTH**

CONNECTION



MCBOX B.SMART



MCBOX B.SMART COMPACT

### PACKAGING

CODE	WEIGHT		PACKAGING			N. BOXES / EUROPALLET	
	KG	LBS	MM	INCH	PCS/BOX	✈	🚚
FO0599C00	2,3	5	260X240X170	10,2X9,4X6,6	1	-	-
FO0599000	5,2	11,5	300X300X180	11.8X11.8X7.1	1	-	-
FO0599200	5,3	11,6	300X300X180	11.8X11.8X7.1	1	-	-
FO0599150	5,4	11,8	300X300X180	11.8X11.8X7.1	1	-	-



FILTRATION



TANK MONITORING



HOSE REEL



ACCESSORIES



MERCHANDISE

# PIUSI

B

ANY BIODIESEL

A

AIR

A

ANTIFREEZE

Ad

AdBlue®

B

BIODIESEL

D

DIESEL

F

FOOD

G

GASOLINE

G

GREASE

K

KEROSENE

O

OIL

W

WATER

W

WINDSCREEN

## CONNECTION SCHEME



PUMP CONTROL



PULSE METER INPUT



TANK LEVEL INDICATOR



NOZZLE SWITCH



## IN THE BOX

- MCBOX B.SMART UNIT
- DRIVER ACCESS ADD-ON
- INSTRUCTION MANUAL

## DETAILS



SHUTTER



B.SMART MOBILE APP



B.SMART CLOUD SOFTWARE



EASY ACCESS TO CONNECTION

## DIMENSIONS

### MCBOX B.SMART

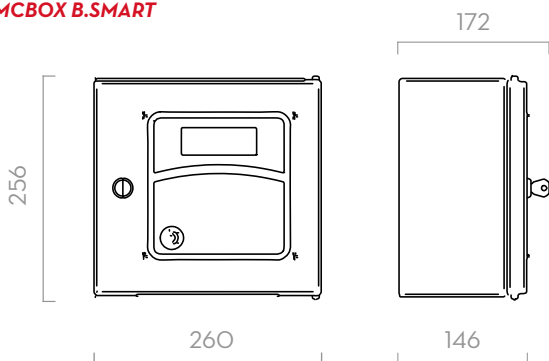

### MCBOX B.SMART COMPACT

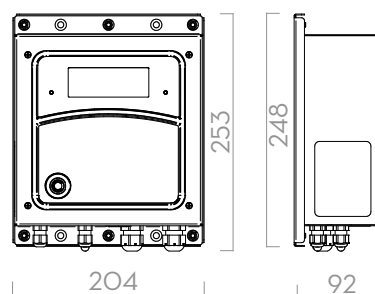

Dimensions expressed in millimeters

## TECHNICAL DATA

CODE	DESCRIPTION	FLUIDS TYPE	VOLTAGE				B.SMART CLOUD
			AC V./HZ	DC VOLT	POWER WATT	AMP. MAX.	
FO0599C00	MCBOX B.SMART 100-240V C 10 ACCESS - COMPACT	ANY FLUID	100-240V 50/60 HZ	-	5 W	15 A	INCLUDED
FO0599000	MCBOX 100-240V B.SMART 10 DRIVERS	ANY FLUID	100-240V 50/60 HZ	-	5W	15 A	INCLUDED
FO0599200	MCBOX 100-240V B.SMART 10 DRIVERS 2 PUMPS	ANY FLUID	100-240V 50/60 HZ	-	5W	15 A	INCLUDED
FO0599150	MCBOX B.SMART 12V/24V 10 ACCESS	ANY FLUID	-	12/24 V	5W		INCLUDED